

MOBILE VIDEOWALL TROLLEY PDVWM 2X2 46 55 L

ORDER CODE: 100013262

Mobile Videowall Trolley for 2x2 installations of NEC MultiSync® 46" and 55" XUN/V, XS and P Series.

This videowall Trolley provides tool-less micro adjustment for precise display alignment along with the strength to hold up to 4 displays. A security screw locking mechanism ensures that the displays stay in the location intended for perfect viewing positioning. With 360° swivel, the durable swivel casters roll smoothly offering easy maneuverability.

TOOL-LESS MICRO ADJUSTMENT

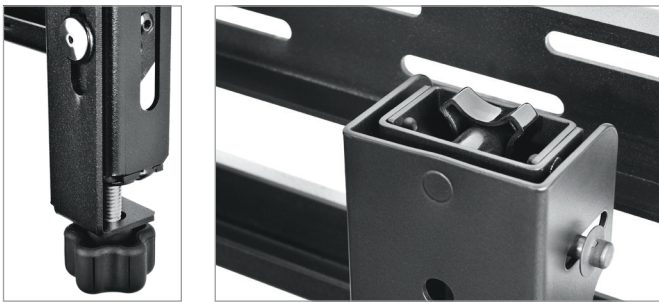

PDVWM 2x2 46 55 L



PDVWM 2x2 46 55 L



Delivering Genuine Benefits

Free standing videowall solution for 2x2 display configurations

Tool-less micro adjustments at 8 point seamlessly align the displays

Multiple mounting slots allow for multiple height options

With strong legs, paired with horizontal supports, the wall cart holds a maximum load of 227kg

Lockable 127mm casters enable safe and easy maneuverability over various flooring surfaces

Cable management through the stand upright columns

Base cover with internal media player shelf, hides cables for a clean appearance

Converts from a trolley to a stand with optional Cart Feet FT01



MOBILE VIDEOWALL TROLLEY PDVWM 2X2 46 55 L

ORDER CODE: 100013262

TECHNICAL DRAWINGS

PDVWM 2X2 46 55 L

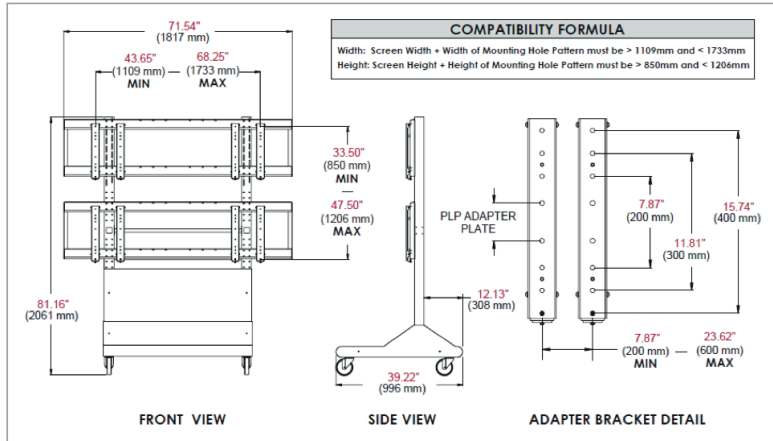

TECHNICAL SPECIFICATIONS

ORDER CODES	
PDVWM 2x2 46 55 L	100013262
FT01	100013264
MIN. DEPTH	990,6 mm
VESA PATTERN	200 x 200; 600 x 400
CONFIGURATION	
Configuration	2x2; 2x1
Orientation	Landscape
Max. weight capacity	227 kg
MECHANICAL	
Package Dimensions (H x W x D)	2159 x 952,5 x 317,5 mm
Shipping Weight	143 kg
Weight of Trolley	134 kg
Shipping Content	Cart frame, 127mm casters, adapter brackets, cart base cover and mounting hardware
OTHER SPECIFICATIONS	
Supported NEC Public Displays	MultiSync® 46" and 55" XUN/V, XS and P Series
Videowall options	Over Frame Kit (KT-46UN-OF, KT-46UN-OF2, KT-55UN-OF); Remote Control Kit (KT-RC); Calibration Kit (KT-LFD-CC)
Certificates / Standards	UL Listed, RoHs
Warranty	3 years
For additional pictures and Solutions overview, Visit www.nec-display-solutions.com for details.	

This document is © Copyright 2012 NEC Display Solutions Europe GmbH. All rights are reserved in favour of their respective owners. The document, or parts thereof, should not be copied, adapted, redistributed, or otherwise used without the prior written permission of NEC Display Solutions Europe GmbH. This document is provided "as is" without warranty of any kind whatsoever, either express or implied. Errors and omissions are excepted.

NEC Display Solutions Europe GmbH may make changes, revisions or improvements in, or discontinue the supply of any product described or referenced in this document at any time without notice. 19. February 2013

NEC Information:

Call: +49 (0)89/99 699-0

Email: infomail@nec-displays.com

www.nec-display-solutions.com

Empowered by Innovation

